

MULTISP PARTS[®]

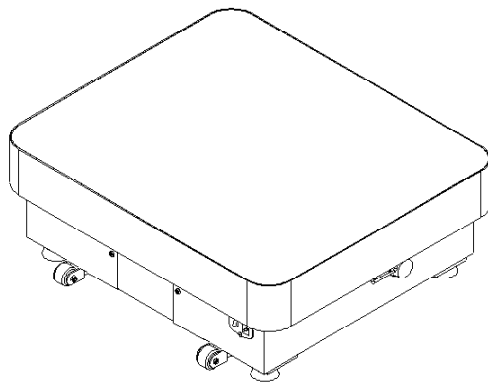

- G-6 G-10M G-10L G-30
- G-1D G-2D G-6D

G-POWER
Linear motion platform

INDEX

IMPORTANT NOTICE.....	P. 1-2
INSTALLATION INSTRUCTIONS.....	P. 3
OPERATION AND REMOTE CONTROL INSTRUCTIONS.	p. 4
REMOTE PROGRAMS.....	P. 5
OPERATION AND MANUAL CONTROL INSTRUCTIONS.	P. 6
SPECIFICATIONS.....	P. 7

- The Specifications and descriptions in this manual were accurate at the time of printing. Improvement is a constant goal at MultiSports; therefore we reserve the right to make changes in specifications at any time without notice and without incurring obligation.
- The information in this manual is given in good faith. However any person who uses this information in any way, does so entirely at his or her own risk. Neither MultiSports, nor its representatives can accept responsibility for any damage or injury incurred as a result of information presented here except under the terms of warranty of MultiSports products.

Congratulations on your purchase of the new MultiSports equipment. Although we go to the great lengths to ensure the quality of our products, occasionally errors or omissions occur. Should you find a missing or defective part in this product, please contact us within thirty days for a replacement by calling us at 713-460-8188, emailing us at mssales@swbell.net or visiting our web site at www.multisportsfitness.com. ***Please provide the equipment "item number" and "part number" when requesting parts.**

IMPORTANT SAFETY INFORMATION

WARNING:

Before starting any exercise program, it is recommended that you consult your physician, especially for persons with pre-existing health problems. **Please consult your physician before using this equipment, if any, but not limited to the following health condition exists**

Heart Problem or Cardiovascular Diseases
Serious Internal Organ Diseases or Medical Conditions
Serious Arthralgia or Athr-illness
Pregnant or Active Menstruation
Hernia or History of Hernia
Serious Hemicranias
Pelvic Problems
Spinal Abnormality
Serious Diabetes
Serious Osteoporosis
Epilepsy
Malignancy or Cancer
Trauma, Inflammation or Recovery from Surgery
Transplanted or Artificial Organs
Recovery from Recent Treatment

Before using the new equipment, please review this manual to learn about the features, functions, and safety operations. Should you experience any irregular physical conditions such as dizziness, severe muscle or joint pain, pain in your chest or should any other symptoms appear: **STOP USING THE EQUIPMENT** and consult with your physician immediately. ****MultiSports assumes no responsibility for personal injury or property damage sustained by or through the use of this product.****

SAFETY TIPS AND PRECAUTIONS:

1. Read all instructions in this manual before using this equipment. It is the owner's responsibility to ensure that all users of this equipment are thoroughly informed of all warnings and precautions. Use this equipment for its intended use as described in this manual.
2. Securely tighten all nuts and bolts and inspect and tighten all parts each time you use the equipment. ****Replace any worn parts immediately and if you find that any repairs are needed, please keep the equipment out of use until repair.****
3. This equipment requires a dedicated circuit as 110V/220V 15/10 AMP separately that is not shared by any other electrical appliances. Failure to do so can damage the electronics and the motor, and will void the warranty.

4. To reduce the risk of electric shock, always unplug the power cord from electrical outlet immediately after use, before cleaning, assembling, or servicing.
5. Never leave the equipment unattended when plugged in. Disconnect by turning off the power switch and unplugging from outlet. Do not switch off until the platform has come to complete stop.
6. Never place hands or feet under or near the gap of the equipment.
7. Do not pull the equipment by the power cord and keep power cord away from heated source, open flame and water.
8. Never operate the equipment if it has been dropped or damaged, or exposed to water
9. The equipment should only be used on a level surface and is designed for indoor use only. **DO NOT USE** with bare feet, wearing sandals, or wearing only socks or stockings.
10. Warm up before you start using the equipment to prevent injuries
11. It is recommended that you do not initiate using this equipment within 40 minutes after a meal.
12. Start using this equipment with the low intensity (levels 1-3) and build gradually.
13. It is recommended that users do not use the equipment for more than 15 minutes at a time. There is an automatic time off after 15 minutes.
14. Keep small children and pets away from the equipment at all times.
15. Appropriate clothing should be worn while using the equipment. Do not wear or carry fragile or delicate items. Never wear loose clothing that could be caught in moving parts. It is recommended that athletic support clothing be worn for both men and women. Athletic shoes should always be worn while using the equipment. **DO NOT USE** with bare feet, wearing sandals, or wearing only socks or stockings.
16. Do not drink or eat while using the equipment.
17. **DO NOT USE** the equipment around water or while you are wet. Using the unit around a pool, hot tub, and sauna or in the environment of humid, wet, hot or dirty will void the warranty and is potentially hazardous.
18. Do not place heavy articles on the equipment while not in use.
19. Do not use any volatile solutions or alcohol to clean the equipment or upholstery.
20. Please reference the Specifications on Page 6 for Max User Weight.

Installation Instructions

INSTALLATION INSTRUCTIONS

1. Remove the equipment from the box and set aside the packing material and empty box until the equipment is fully operated. (The equipment weighs from 74 lbs to 331 lbs depending on the model, assistance may be needed during the installation.)
2. Place the equipment on an even surface, otherwise excessive noise and faster wear-out may result.
3. If the floor/equipment is not even, tilt the equipment to sit on its side. Use the 14mm Hex Wrench to release the Nut, turn the Adjustable Rubber Foot to the desired height and then tighten the nut.

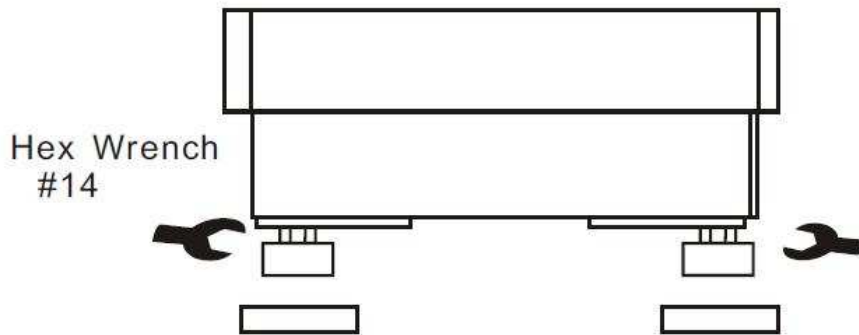

Operation/Remote Control Instructions

OPERATION INSTRUCTIONS

1. Plug the power cord to a dedicated outlet.
2. Turn on the power switch, which located next to power socket.
3. Use the remote control to operate (9V battery required)

REMOTE CONTROL INSTRUCTIONS

FUNCTION BUTTONS

STOP To STOP the equipment or to change the settings.

Auto 1, Auto 2 and Auto 3 To use one of the preset Program 1, Program 2 and Program 3.

1-7 Preset frequencies. (1 as the lowest and 7 as the highest)

LED Light The LED light will be on when any button is pressed and off when the button is released.

1. Press **1-7** button to start a fixed frequency program.
2. Press **Auto 1-3** to start a preset program with various frequencies.
3. Press **STOP**, to stop any program.

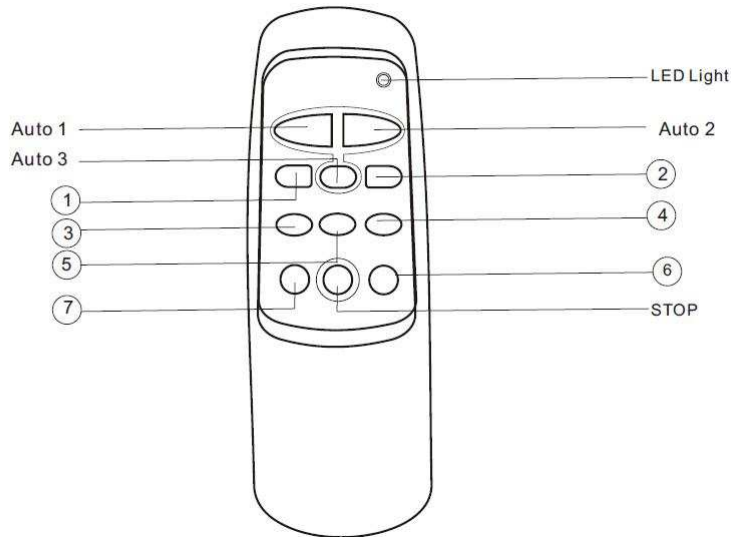

G-POWER REMOTE CONTROL FREQUENCIES

	G-1D	G-2D	G-6 / G-6D	G-10M	G-10L	G-30
AUTO 1	5HzX50sec +20HzX10sec /cycle	2.5HzX50sec +10HzX10sec /cycle	3HzX50sec +7HzX10sec /cycle	2HzX50sec +6HzX10sec /cycle	2HzX50sec +6HzX10sec /cycle	1.5HzX50sec +2.7HzX10sec /cycle
AUTO 2	5HzX50sec +25HzX10sec /cycle	2.5HzX50sec +12HzX10sec /cycle	3HzX50sec +8HzX10sec /cycle	2HzX50sec +7HzX10sec /cycle	2HzX50sec +7HzX10sec /cycle	1.5HzX50sec +3.0HzX10sec /cycle
AUTO 3	5HzX55sec +30HzX5sec /cycle	2.5HzX55sec +15HzX5sec /cycle	3HzX55sec +10HzX5sec /cycle	2HzX55sec +8HzX5sec /cycle	2HzX55sec +8HzX5sec /cycle	1.5HzX55sec +3.5HzX5sec /cycle
1	5 Hz	2.5 Hz	3 Hz	2 Hz	2 Hz	1.5 Hz
2	8 Hz	4 Hz	4 Hz	3 Hz	3 Hz	1.8 Hz
3	12 Hz	6 Hz	5 Hz	4 Hz	4 Hz	2.1 Hz
4	15 Hz	8 Hz	6 Hz	5 Hz	5 Hz	2.4 Hz
5	20 Hz	10 Hz	7 Hz	6 Hz	6 Hz	2.7 Hz
6	25Hz	12 Hz	8 Hz	7 Hz	7 Hz	3.0 Hz
7	30 Hz	15 Hz	10 Hz	8 Hz	8 Hz	3.5 Hz

Formatted

Operation/Manual Control Instructions

OPERATION AND MANUAL CONTROL INSTRUCTIONS

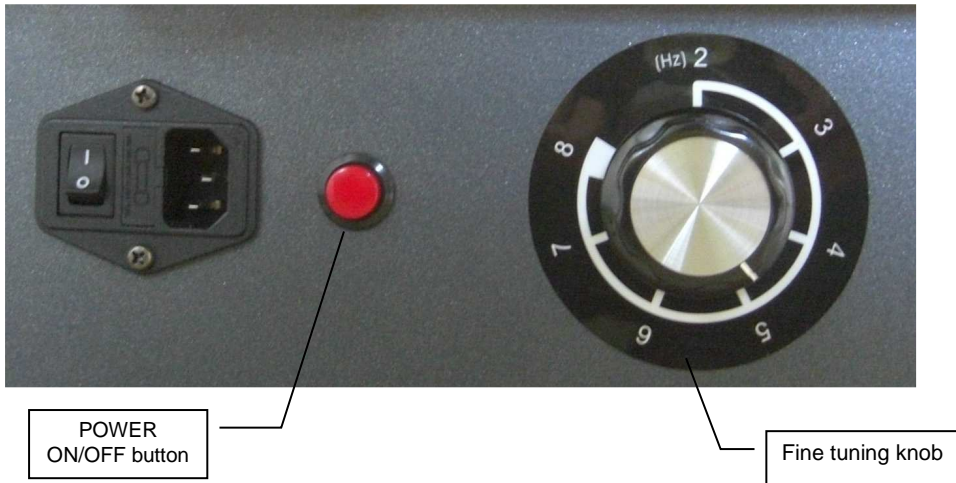

1. Press the "STOP" button on the remote to turn off the Remote control function, then press the manual power ON/OFF button for manual operation
2. Use the manual fine tuning knob for frequency control
3. Press the manual power ON/OFF button to stop the machine. Or, press any button of the remote control for remote control operation.

Specifications

SPECIFICATIONS

Item No.	Weight (lbs)	Dimensions (LXWXH)	Frequency (Hz)	Amplitude (m/m)	Maximum Load (lbs)	MOTOR
G-Pro	331	33" x 30" x 60"	5 ~ 20	1.5 ~ 7	660	AC
G-30	243	33" x 31" x 15"	1.5 ~ 3.5	30	660	AC
G-10L	298	74" x 30" x 11"	2 ~ 8	10	660	AC
G-10M	192	42" x 23" x 11"	2 ~ 8	10	660	AC
G-6	123	27" x 23" x 10"	3 ~ 10	6	660	AC
G-6D	110	27" x 23" x 10"	3 ~ 10	6	400	DC
G-2D	90	23" x 23" x 9"	2.5 ~ 15	2	400	DC
G-1D	74	23" x 23" x 9"	5 ~ 30	1	400	DC



4660 Pine Timbers, Suite 138, Tx77041

Phone: 713-460-8188 Fax: 713-460-8180

Web-site: www.multisportsfitness.com E-mail: mssales@swbell.net